

## Level transmitters and indicators

### Series LU



#### Ultrasonic level transmitter and indicator for liquids and solids

- No contact with the product
- Compact design with polycarbonate housing (electronics and display). Remote display available on request
- Very good resistance in corrosive environments, outdoors applications,...
- Easy to program by means of keyboard-display
- Level indication with automatic compensation of temperature changes
- Low power consumption
- Measuring range:
  - Liquids:
    - Model LU91: 0.30 ... 6 m
    - Model LU921: 0.30 ... 5 m
    - Model LU93: 0.45 ... 12 m
    - Model LU923: 0.45 ... 10 m
  - Solids:
    - Model LU91: 0.30 ... 3.5 m
    - Model LU921: 0.30 ... 2.5 m
    - Model LU93: 0.45 ... 7 m
    - Model LU923: 0.45 ... 5 m
- Accuracy:  $\pm 2$  mm (between 0.3 and 2 m)
- Connections:
  - Models LU91 / LU921: G2 thread
  - Models LU93 / LU923: G2½ thread
 Others on request
- Materials: PP, PVDF
- Continuous level measurement, with 4-20 mA output
- Maximum-minimum level alarms, in 4-wire version (Models LU91 and LU93)
- Optional: HART communication protocol



## Working principle

A transducer sends short ultrasonic pulses to a product surface. The reflection of these pulses is received back by the same transducer.

The ultrasonic waves travel at the speed of sound. The time passed since the emission of the signal until it is reflected on the product surface (T1) plus the time necessary to receive the signal back on the transducer (T2) determines the distance between the sensor and the product.

The calculation of this distance is carried out by means of a micro-processor with a powerful and smart software which selects the correct echo level among all the echos produced by the internal elements of the tanks.

A temperature sensor built-in the transducer provides the real working temperature to the micro-processor, that makes the proper calculation corrections of the measured distance.

A change in product does not affect the correct performance of the instrument, so it is not necessary to re-adjust the unit for each new product. The non-invasive level transmitter makes installation and maintenance easier.

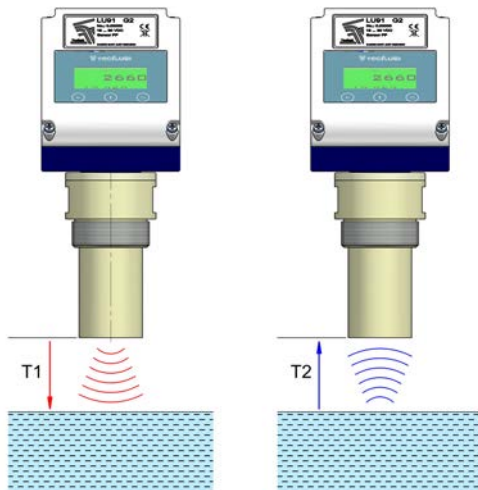

## Applications

- Level control in storage tanks of chemical and petrochemical products, treated water, waste water, rainwater,... And food products
- Level control in storage silos of powder, granular products,...
- Flow measurement in open channels, in combination with the electromagnetic sensor series FLOMAT (signal integration software not supplied)
- Control of paper, cardboard, steel and plastic reels
- Level control in intermediate tanks for processes such as pumps start-stop, valve opening-closing, etc.

## Models

- LU91 ... 93 4-wire system
- LU91H ... 93H 4-wire system with HART protocol
- LU921 ... 923 2-wire system
- LU921H 2-wire system with HART protocol

## Technical data

- **Accuracy:**  $\pm 2$  mm (between 0.3 and 2 m)
- **Resolution:** 1 mm
- **Uncertainty:**  $< 0.25\%$  of the span
- **Repeatability:**  $< 0.25\%$  of the span
- **Measuring range:**
  - LU91: liquids: 0.30 ... 6 m ; solids: 0.30 ... 3.5 m
  - LU921: liquids: 0.30 ... 5 m ; solids: 0.30 ... 2.5 m
  - LU93: liquids: 0.45 ... 12 m ; solids: 0.45 ... 7 m
  - LU923: liquids: 0.45 ... 10 m ; solids: 0.45 ... 5 m
- **Measurement interval:** 200 ms
- **Ultrasonic beam width:**  $14^\circ$  at  $-3\text{dB}$

Reference conditions: Temperature:  $+18 \dots +30^\circ\text{C}$

Air relative humidity:  $45 \dots 75\%$  ; Air pressure:  $860 \dots 1060$  mbar

- **Fluid temperature:**  $-40^\circ\text{C} \dots +80^\circ\text{C}$
- **Ambient temperature:**
  - Transducer:  $-40^\circ\text{C} \dots +80^\circ\text{C}$
  - Electronics:  $-40^\circ\text{C} \dots +60^\circ\text{C}$
- **Working pressure:** min. 0.7 bar abs ; max. 4 bar abs
- **Materials:**
  - Sensor: PP / PVDF
  - Housing / Seal Polycarbonate (UV resistant) / NBR
- **Connections:**
  - LU91 / LU921: G2 or 2" NPT
  - LU93 / LU923: G2½ or 2 ½" NPT

Other connection standards on request

- **Weight:** from 1.8 to 2.5 kg depending on process connection
- **Resistance to mechanical vibrations** of 4G between 5 and 100Hz
- **Ingress protection:** IP67
- **4-20 mA output** active or passive
- **Maximum and minimum level alarms**, full range adjustable, only for 4-wire models.
  - NPN opto-isolated transistor output: V max.: 30 VDC ; I max.: 30 mA
- **Power supply:**
  - Models LU921 / LU923:
    - 2-wire: 12 ... 36 VDC
  - Models LU91 / LU93:
    - 4-wire: 18 ... 30 VDC (special: 14 ... 25 VDC)
- **Power consumption:**  $< 20$  mA (2-wire) ;  $< 60$  mA (4-wire)
- **Cable entries:** 3 x PG11 (cables  $\varnothing_{\text{ext}}$  between 6 ... 10 mm)
- **Programming by means of keyboard and display** (remote display available on request)
- **Optional HART protocol (except model LU923)**

# Level transmitters and indicators

## Series LU

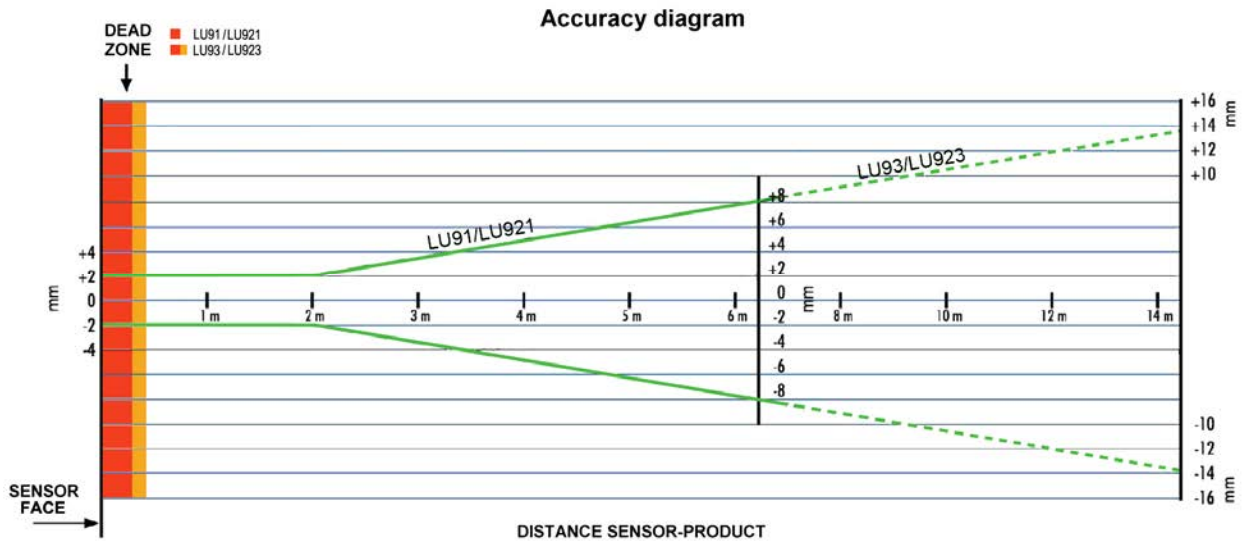

### Materials

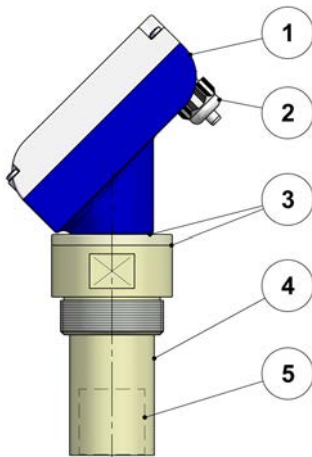

N°	Description	Materials
1	Housing	Polycarbonate *
2	Seal	NBR
3	Sensor	PP PVDF
4	Transducer	PVDF

\* UV resistant

### Dimensions

Models LU91 / LU921

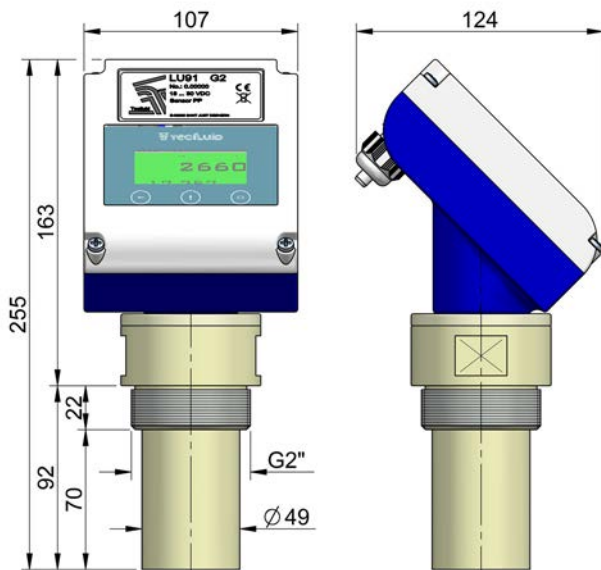

Models LU93 / LU923

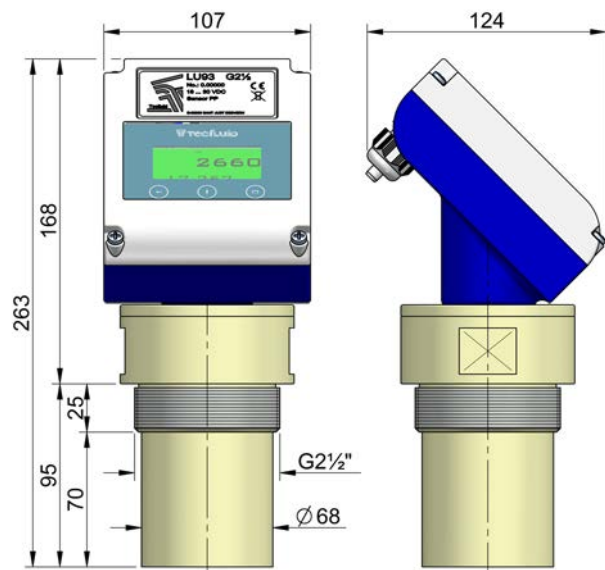

## Operation

The installation of the level transmitter must be carried out making sure that the transducer flat face is as parallel as possible to the product surface, in order to guarantee a correct measurement.

The minimum distance with respect to the tank wall must be at least 200 mm, avoiding the sensor to be centred in the tank, especially in cases with agitators or formation of emptying cones (Fig. 1).

### Dead zone

The dead zone (ZM) is a zone close to the transducer, where the instrument is unable to make any measurement (Fig. 1).

For model LU91 / LU921, dead zone is 300 mm, while for model LU93 / LU923, it is 450 mm.

### Reduction of dead zone

In case of being necessary to reduce the dead zone, reflecting elements can be installed. This allows measurements to be made up to the maximum height of the tank (Fig. 2).

### Nozzles

The length of the sensor must be taken into account and it must be ensured that it protrudes at least 10 mm from the edge of the nozzle (Fig. 3).

d	l	h max.
50 mm (2")	> 10 mm	80 mm (3")
65 mm (2 1/2")	> 10 mm	80 mm (3")
100 mm (4")	> 10 mm	300 mm (12")
150 mm (6")	> 10 mm	400 mm (16")

## Common installations

### Open channels

Level measurement in open channels.

### Open tanks

Classical application of measurement and control of liquid level, even with suspended solid particles (Fig. 4).

### Pressurized tanks

Level control of all kind of liquids, with maximum pressure of 4 bar abs. When working pressure is lower than 0.7 bar abs other measurement systems must be used, such as float type, radar, guided radar, etc..

### Tanks with conical bottom

Except in tanks with conical bottom, it can be advantageous to install the sensor in the center of the tank, since in almost all the cases it allows to make closer measurements to the bottom of the tank (depending on tank diameter). The formation of emptying cones must be taken into account (Fig. 5).

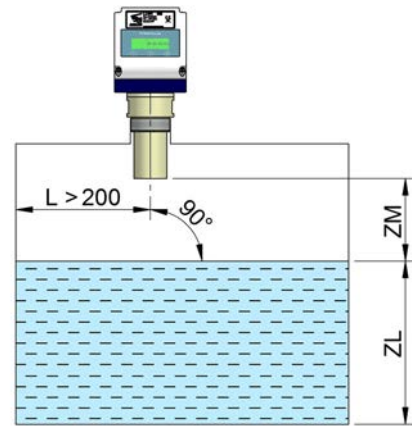

Fig. 1

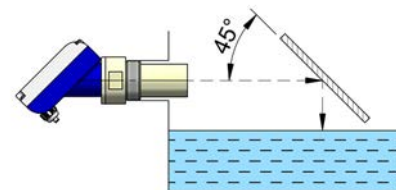

Fig. 2

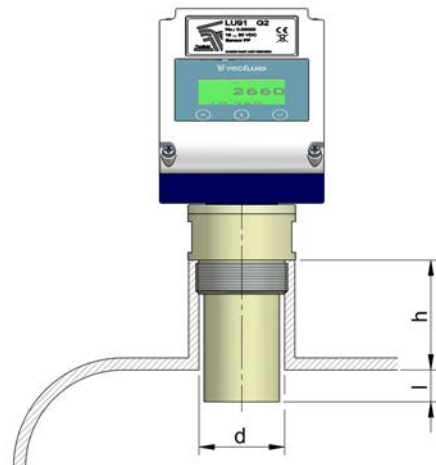

Fig. 3

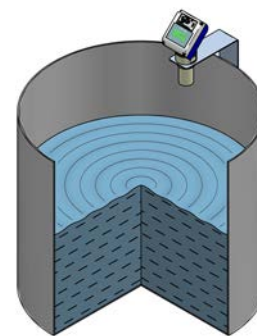

Fig. 4

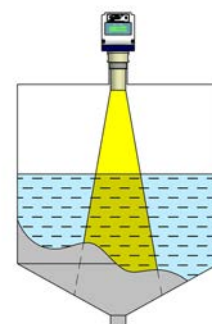

Fig. 5

# Level transmitters and indicators

## Series LU

### Mud containers

Control of containers filling, by means of conveyors belts, with mud coming from water treatment processes. The minimum distance to tank walls must be bigger than 200 mm (Fig. 6).

### Product inlets or filling areas

It must be ensured that the sensor is installed above the product surface, and not around the filling area or close to the product inlet (Fig. 7).

In case of partial or total presence of thick foams on the product surface and for open tanks with possible sudden level changes, strong winds or turbulences caused by cyclones, the sensor must be mounted inside a protecting tube with length equal to the minimum measuring level, planning an aeration orifice of around 5 ... 10 mm of diameter (Fig. 8).

### Agitators

The disturbing echo caused by the agitator must be stored into sensor memory, so it is ensured that the reflections due to the agitator will not be taken into account in the following measurements (Fig. 9).

### Tanks internal structures

In tanks where there are internal structures such as steps, heating-cooling coils, struts, etc. disturbing echoes which might interfere with the correct echo may occur.

If disturbing echoes cannot be avoided, they can at least be minimized by means of small metallic or plastic covers which diffuse the wave reflections, avoiding the direct reception of said waves by the transducer (Fig. 10).

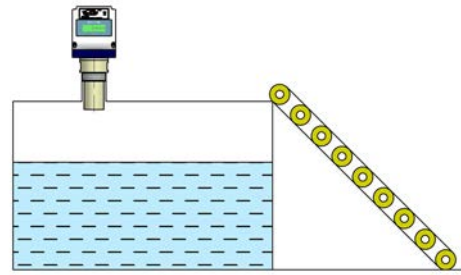

Fig. 6

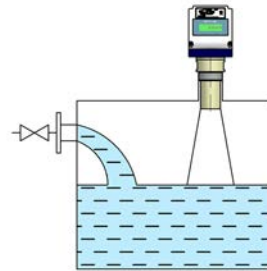

Fig. 7

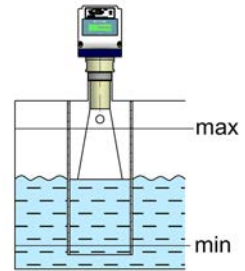

Fig. 8

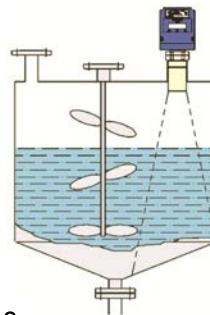

Fig. 9

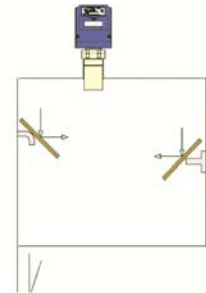

Fig. 10

## HART protocol

The level transmitters series LU are compatible with HART communication protocol. The characteristics details are available in the "Field Device Specification" document. In order to proceed with HART communication, an external resistance (R ext.), of between 200 and 500 Ohm, must be connected to the current loop. The positions where a terminal or a PC with modem HART can be connected are shown in

