

Flow switches Series AD/VH

Flow switch and indicator for liquids and gases

- Suitable for clear, opaque or turbid liquids (series AD & VH), and for gases (series AD)
 - Flow switching by means of magnetic coupling, watertight, no contact between process fluid and switching, indicator or transmitter systems
 - Suitable for installation in horizontal or vertical pipes
 - Robust construction
 - Scales available for H₂O, air, oil, etc. (series AD)
 - Flow rate (for liquids):
 - Series AD: 0.25 ... 270 l/min
 - Series VH: 2 ... 120 m³/h
 - Accuracy for series AD: ±5% f.s.
 - Connections:
 - Series AD: ¼" ... 2 ½" BSP / NPT
 - Series VH: G1 / 1" NPT, to be inserted on a DN32 ... DN500 pipe
 - Materials:
 - Series AD: EN 1.4404 (AISI 316L), aluminium, brass
 - Series VH: EN 1.4404 (AISI 316L), PTFE
 - Flow switching:
 - 1 reed switch (series AD & VH)
 - 2 reed switches (only series AD)
 - 1 or 2 inductive switches (only series AD)
- All switches for series AD are ATEX Ex ia IIC T4...T6 Ga / Ex ia IIIC T85°C Da certified
- Options for model ADI15:
 - Local flow indication
 - Electronic transmitter with 4-20 mA output for safe or hazardous area (Ex ia IIC T4...T6 Ga / Ex ia IIIC T85°C Da protection, ATEX certified). HART protocol available on request



Series AD

Working principle

A spring **M** keeps a disk **B** in zero flow rate position. When the fluid flows through the disk at a specific speed, a force is made on the disk **B**, moving it to an equilibrium position.

The distance covered by **B** depends on:

- The force of the fluid flow **F**.
- The relationship between areas **A** & **B**.
- The force in opposition of the spring **C**.

The equilibrium between forces **F** and the one generated by **C** defines the position of the disk **B**, equivalent to flow rate.

The disk **B**, which contains a magnet **M**, acts over the switches and/or the local indicator.

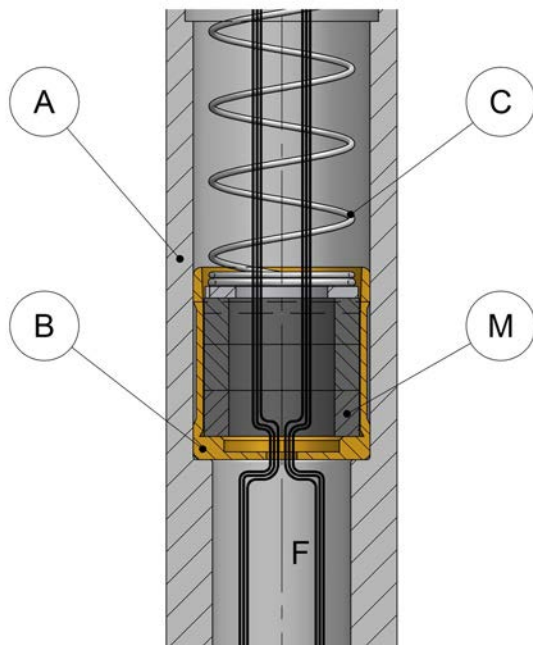

Applications

- Machine or processes cooling
- Hydraulic and lubrication circuits
- Thermal oil circuits
- Gas flow control
- Mechanical fasteners cooling control

Models

- **AD15** with one or two reed switches
- **ADI15** local flow indication optionally with:
 - one or two reed switches
 - one or two inductive switches
 - 4-20 mA transmitter

Technical data

- **Accuracy:** $\pm 5\%$ full scale
- **Scale range:** according to flow rate chart on page 4
- **Scales in l/h, l/min, l/s, m³/h, %, etc.**
- **Connections:** 1/4" ... 2 1/2" BSP / NPT
- **Materials:**
 - Brass from 1/4" to 2"
 - Aluminium from 1 1/4" to 2 1/2"
 - EN 1.4404 (AISI 316L) on request
- **Fluid temperature:** -20°C ... +100°C (max. allowable 120°C)
- **Working pressure:** PN16 (others on request)
- **Vertical or horizontal mounting,** as per customer's request
- **Ex ia IIC T4...T6 Ga / Ex ia IIIC T85°C Da ATEX certificate**

Operation

- Vertical upwards flow (BD)
- Vertical downwards flow (DAB)
- Horizontal flow from left to right (ED)
- Horizontal flow from right to left (DES)

Limit switches and transmitters

- **Reed switches:** SPDT potential free. Polyamide housing and IP65 connector
 - /1A = 1 reed switch
 - /2A = 2 reed switches
- Reed switch technical data:
 - **ADR01:** for sizes 1/4" & 1/2": 0,25 A 175 VDC 5 W
 - **ADR11:** for sizes 3/4" to 2 1/2": 1 A 250 V 60 VA
- **M1-AMD1 ... 2:** 1 ... 2 adjustable inductive switches (+ relays on request)
- **TH6 ... TH6H:** 4-20 mA 2-wire transmitter HART protocol for model TH6H

All switches and transmitters are ATEX available Ex ia IIC T4...T6 Ga / Ex ia IIIC T85°C Da version

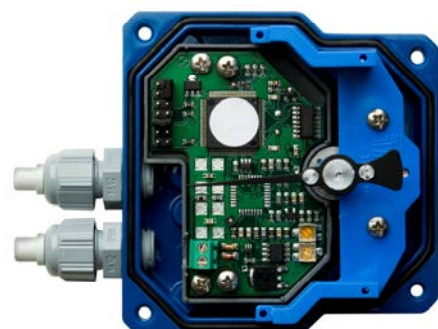

TH6 transmitter

Materials

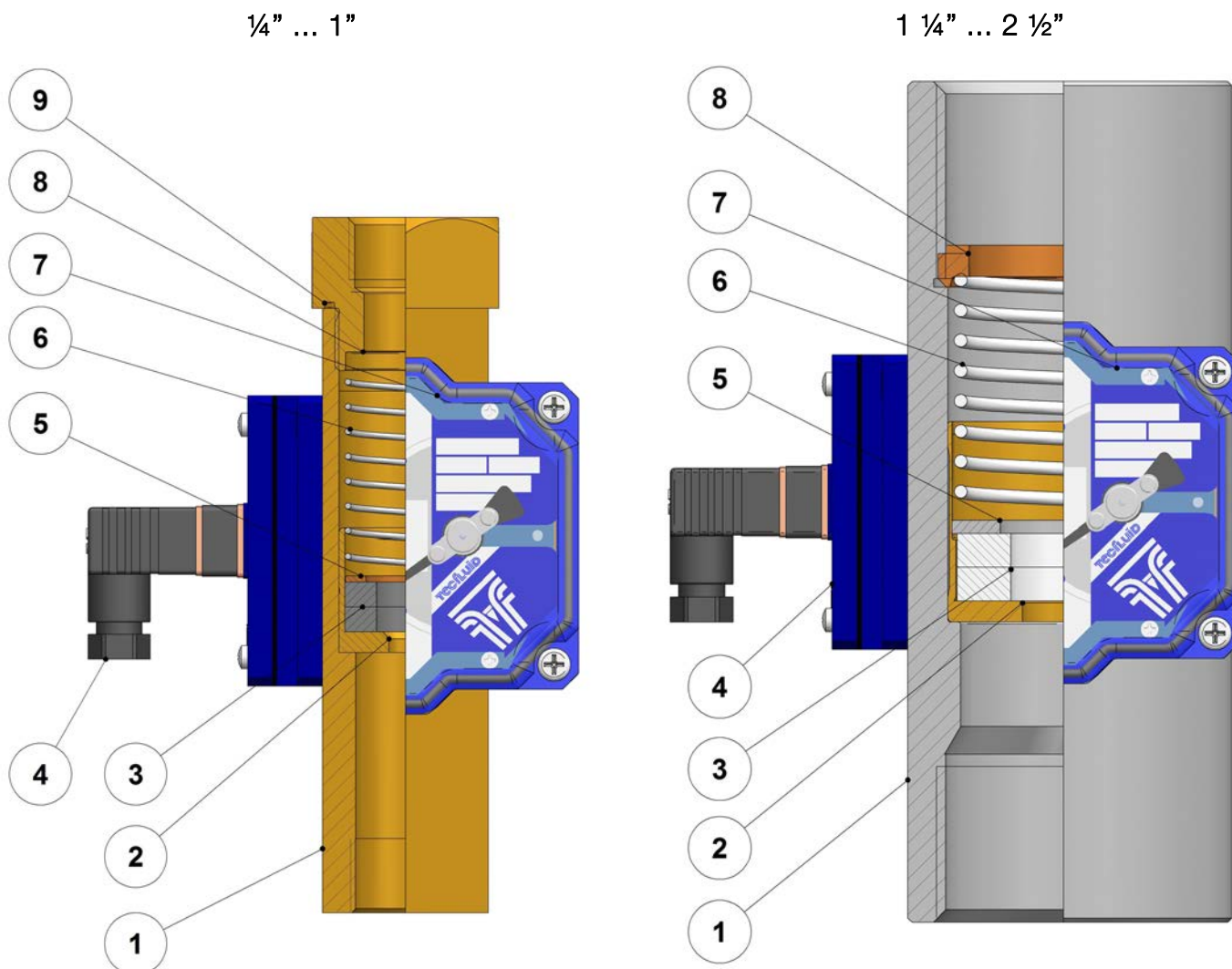

N°	Description	Materials	
		1/4" ... 1"	1 1/4" ... 2 1/2"
1	Body	Brass / AISI 316L / Anodized aluminium *	
2	Disk		
3	Magnet	Ferrite **	
4	Switch	Polycarbonate - PVC - NBR	
5	Washer	AISI 316L	
6	Spring	AISI 302	
7	Housing	Polycarbonate - Coated aluminium	
8	Screw	AISI 316	
9	Gasket	NBR ***	---

* Materials available for each size:

1/4" ... 1" : brass, AISI 316L

1 1/4" ... 2" : brass, AISI 316L, anodized aluminium

2 1/2" : AISI 316L, anodized aluminium

** magnet with plastic coating for applications with corrosive liquids on request

*** other materials on request

Dimensions

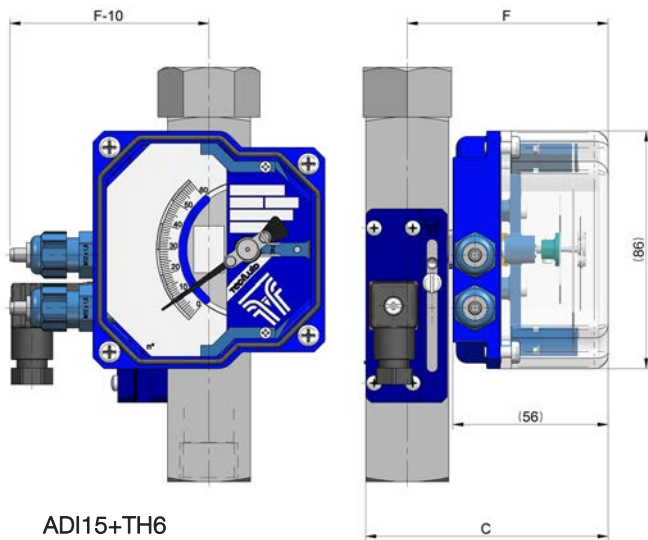
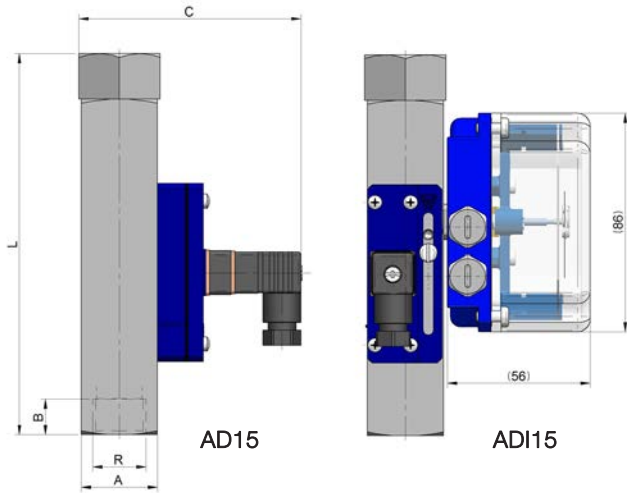

R" (BSP / NPT)	A	B	C	F	L	Weight (kg)
1/4"	□ 30	14	85	70	151	0.9
1/2"	□ 30	14	85	70	151	1.2
3/4"	□ 40	15	95	75	169	1.6
1"	□ 40	15	95	75	169	1.8
1 1/4"	□ 50	27	105	80	160	2.4
1 1/2"	□ 60	27	115	85	180	3
2"	Ø 80	37	134	96	200	3.2
2 1/2"	Ø 100	37	147	97	200	3.6

All dimensions in mm

Flow ranges

R" (BSP / NPT)	Flow scales l/min water
1/4"	0.25-1
	0.5-2.5
1/2"	1-5
	1.5-10
3/4"	2-17
	5-30
1"	6-40
1 1/4"	10-50
1 1/2"	15-70
2"	40-160
2 1/2"	70-220
	100-270

* Equivalent flow ranges for air at 1 bar abs 20°C in NI/min:
l/min H₂O x 8 (approx.)

Mounting

Vertical upwards

Models AD15/BD
ADI15/BD



Vertical downwards

Models AD15/DAB
ADI15/DAB

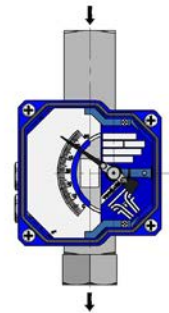

Horizontal /
Left to right

Models AD15/ED
ADI15/ED

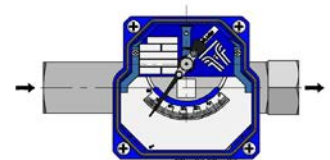

Horizontal /
Right to left

Models AD15/DES
ADI15/DES

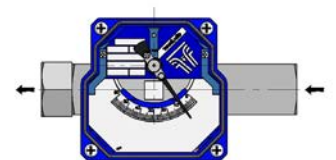

Model AD15

- Flow switch with min-max flow rate reed switches.
- Vertical or horizontal mounting, as per customer's request.
- Adjustable reed switch for the full flow scale, mounted in a polyamide housing, IP65 ingress protection.
- Flow scale in l/h, l/min, l/s, m³/h, %, etc.



Model ADI15

- Local flow indicator, with optional min-max flow rate reed switches, adjustable for the full flow scale and mounted in an IP65 polyamide housing; and/or adjustable inductive switches, mounted in the indicator housing.
- Vertical or horizontal mounting, as per customer's request.
- Aluminium indicator housing with polycarbonate cover, IP65 ingress protection, graduated scale in flow rate units, reading by means of indicating needle.
- Flow and reed switch scale in l/h, l/min, l/s, m³/h, %, etc.

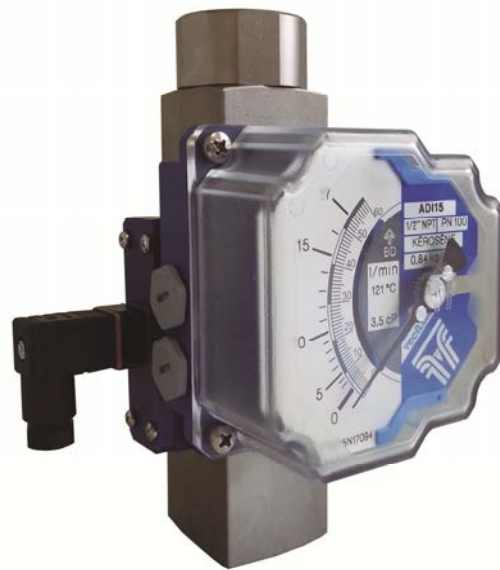

Model ADI15 + TH6

- Same characteristics as model ADI15, including electronic transmitter with 2-wire 4-20 mA output.

Limit switches and transmitters

Adjustable limit switch M1-AMD

Optional for model ADI15.

NAMUR (EN 60947-5-6) 3.5 mm slot type inductive detector activated by vane, mounted in the indicator housing.

- M1-AMD1 ... 2: 1 ... 2 adjustable limit switches
- Power supply: 8 VDC
- Ambient temperature: -25°C ... +70°C
- ATEX certification Ex ia IIC T4...T6 Ga / Ex ia IIIC T85°C Da

Control relay (on request)

NAMUR (EN 60947-5-6) for 1 or 2 inductive detectors.

- Power supply: 24 ... 253 VAC 50-60 Hz
24 ... 300 VDC
- Input: NAMUR Ex ia IIC
- Output: 1 or 2 relay contacts
- Output rating: 2 A 250 VAC 100 VA / 1 A 24 VDC
- Ambient temperature: -20°C ... +60°C



Transmitter TH6



- Power supply: 2-wire system, 12 ... 36 VDC
- Power consumption: max. 20 mA
- Analog output (4-20 mA):
 - Error: < 0,6% of the magnet position
 - Maximum load in 4-20 mA loop: 1.1 kΩ (with 36 VDC power supply)
- Ambient temperature: -5°C ... +70°C
- Transmitter connector: Packing gland M12x1.5
- Optional: ATEX certification Ex ia IIC T4...T6 Ga / Ex ia IIIC T85°C Da, with model TH6 Ex
- Optional: HART protocol, with model TH6H

Series VH

Working principle

A liquid flows inside a pipe fast enough to move a paddle, which at the same time moves a permanent magnet that acts over the reed switch. The magnet-reed switch system is isolated from the liquid.

The flow switching point is positioned between 30° and 45° from the zero position.

Applications

- Hydraulic and heating-cooling circuits
- Chemical, petrochemical and pulp & paper industry
- Water treatment, power plants
- Swimming pools & fire protection systems

Models

- VH35 / SS ... PTFE horizontal pipe
- VH37 / SS BD vertical pipe with upwards flow, with spring
- VH39 / PTFE BD vertical pipe with upwards flow, with magnetic spring

Technical data

- **Flow detection** by means of oscillating paddle
- **SPDT potential free reed switch**, mounted in the body, not wetted by the liquid
- **Connections:** G1 (1" NPT on request)
- **Materials:** EN 1.4404 (AISI 316L), PTFE
Others on request
- **Fluid temperature:** -40°C ... +125°C (max. allowable 150°C)
- **Working pressure:**
 - AISI 316L body: PN25 (others on request)
 - PTFE body: PN10
- **Mounting:** horizontal or vertical upwards pipe

Operation

- Vertical upwards flow (BD)
- Horizontal flow from left to right
- Horizontal flow from right to left

Limit switches

- **Reed switch:** potential free switch
Contact rating:

Maximum switching power: 5W

Maximum switching voltage: 175 VDC

Maximum switching current: 0.25 A



- Electrical connection: connector IP65 DIN 43 650-A

- Suitable for hazardous area, considered as "Simple apparatus"

Materials

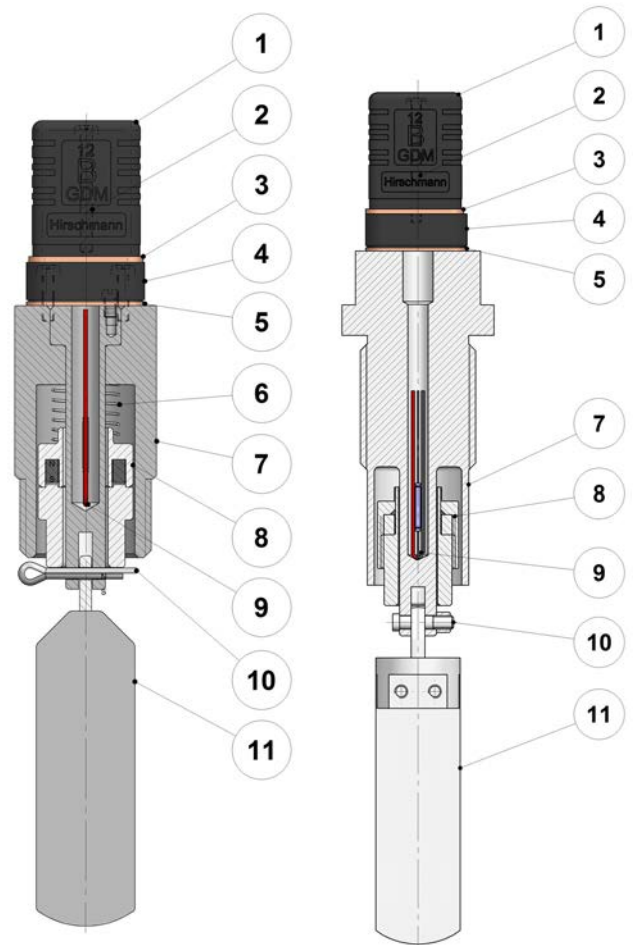

N°	Description	Materials	
		VH / SS	VH / PTFE
1	Connector		Polyamide
2	Screw		AISI 304
3	Gasket		NBR
4	Connector base		Polyamide
5	Gasket		NBR
6	Spring	AISI 304	---
7	Body	AISI 316L	PTFE
8	Magnet holder	PVDF	PTFE
9	Reed switch		Glass
10	Pin	AISI 316	PTFE
11	Paddle	AISI 316L	PTFE

Dimensions

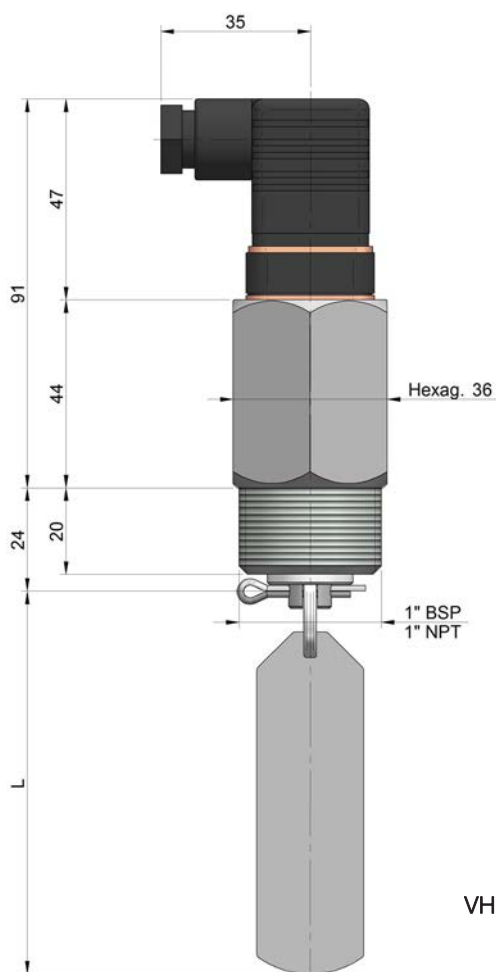

VH35 / SS

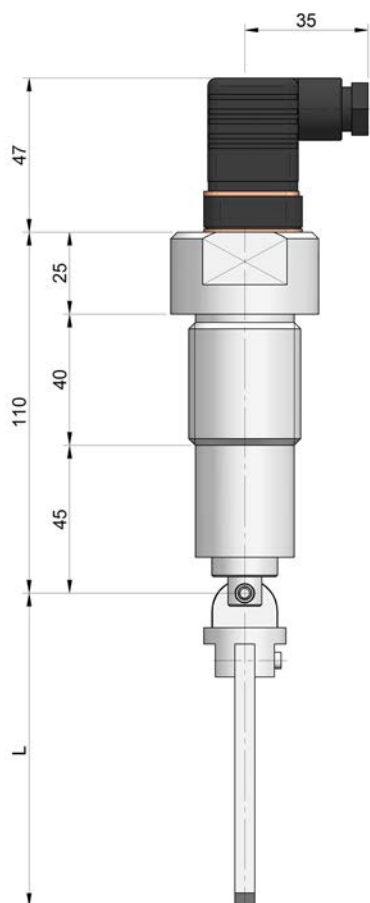

VH35 / PTFE

Switching flow rates

DN mm	DN inch	Switching flow rate ⁽¹⁾ m ³ /h	L mm
32	1 ¼"	2	26
40	1 ½"	2.5	34
50	2"	3	40
65	2 ½"	4	55
80	3"	5	65
100	4"	10	90
125	5"	10	115
150	6"	12	140
200	8"	25	185
250	10"	30	230
300	12"	50	280
350	14"	60	330
400	16"	80	380
450	18"	100	415
500	20"	120	450

⁽¹⁾ Approximate flow rates

Mounting

Horizontal / left-right or right-left:
model VH35



VH35 / SS

VH35 / PTFE

Vertical upwards:
model VH37 / 39 BD



VH37 / SS BD

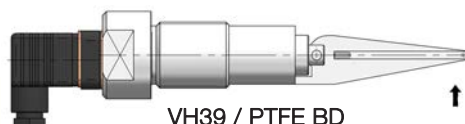

VH39 / PTFE BD

PRESENCE IN MORE THAN 50 COUNTRIES ALL OVER THE WORLD



TECFLUID
The art of measuring



Quality Management System ISO 9001 certified by **Applus[®]**

Pressure Equipment Directive 97/23/CE certified by **Lloyds Register**

ATEX European Directive 94/9/CE certified by 

HART[®] is a registered trademark of HART Communication Foundation

The technical data described in this specification sheet is subject to modification without notification if the technical innovations in the manufacturing processes so require.